

# STI Extinguisher Stopper®

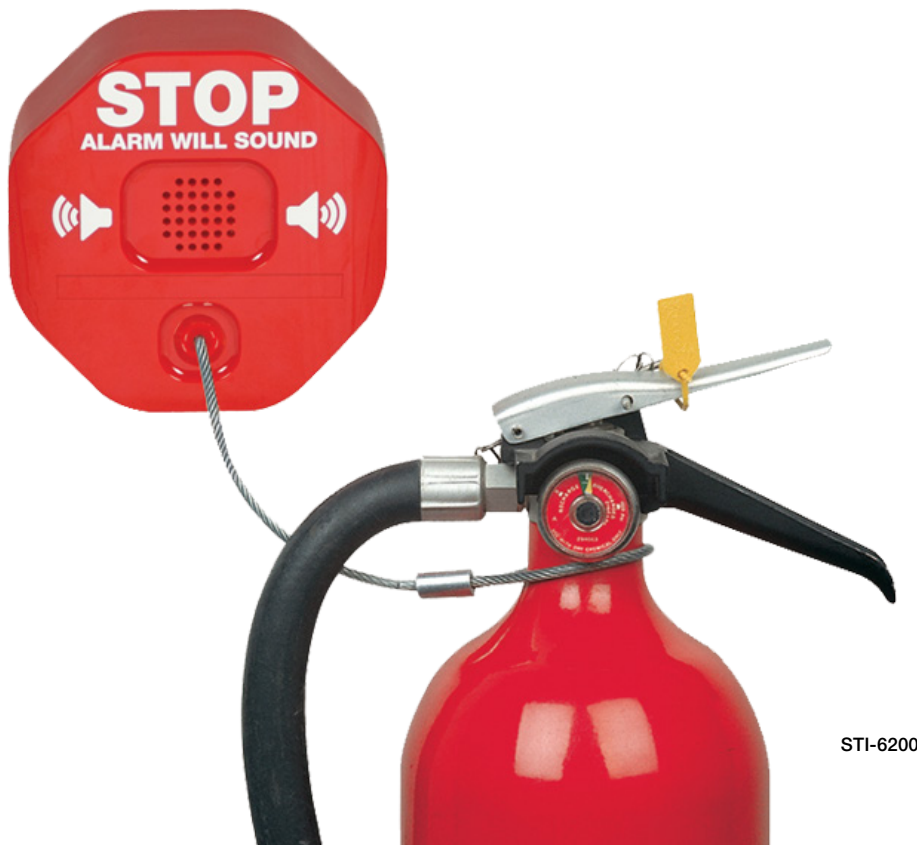

STI-6200

## PRODUCT OVERVIEW

If you are fed up with replacing and recharging your fire extinguisher, this sturdy, tamperproof, self-contained device is the answer. It has proven highly effective in helping prevent theft, misuse and vandalism of fire extinguishers. The Extinguisher Stopper will leave the extinguisher accessible for emergencies and will not interfere in the event of a real fire.

## HOW IT WORKS

If the protected fire extinguisher is moved from its normal position, the device emits a piercing alarm. Also, the highly visible stop sign design and the words "STOP, ALARM WILL SOUND" discourages wrongful use. The device is easy to install and a deactivation cable is supplied for ease in servicing the extinguisher. A 9 VDC alkaline battery is included

## KEY FEATURES

### General Information

- It has proved highly effective in helping prevent theft, misuse or vandalism of fire extinguishers.
- Does not interfere with use of protected firefighting equipment.
- Three year guarantee against breakage of the polycarbonate housing (one year on electromechanical and electronic components).

### Design

- Compact design (136mm diameter x 50mm deep) mounts easily next to the extinguisher.
- Add warning in second language with provided labels (21 languages).

### Construction

- Virtually indestructible polycarbonate housing.
- Polycarbonate is UV-stabilized.
- Self-contained device, tamperproof and sturdy.

### Installation

- Easy to install.
- Deactivation cable is supplied for ease of servicing the extinguisher.
- Supplied complete with an operating cable kit, allowing the connection around the neck of the extinguisher.

### Options

- Option of coming with a built in wireless device, used in conjunction with the 8-Channel Receiver.
- Deactivation cable is provided for service by authorised personnel.

### Remote Wireless Monitoring of Fire Extinguishers

- You can now be alerted to any vandalism or authorised use of a fire extinguishers in the event of an emergency. Upon activation, the Extinguisher Stopper (when fitted with an optional transmitter and sounder) will emit a localised alarm as well as triggering the 4-Channel (STI-34104) or 8-Channel Receiver (STI-34108), providing a visual and audible indication, remotely.

# STI Extinguisher Stopper®

Dimensions and Technical Information

## MODELS AVAILABLE

- STI-6200** Extinguisher Stopper (includes operating cable kit)
- STI-6200WIR** Wireless Extinguisher Stopper
- STI-6200WIR4** Wireless Extinguisher Stopper with 4-Channel Receiver
- STI-6200WIR8** Wireless Extinguisher Stopper with 8-Channel Receiver

**Accessories:**

- KIT-18015-9** Service/deactivation cable
- KIT-18015-RC** Operating cable kit (includes operating cable and seal)
- STI-6206** Seal
- KIT-H19016** Tamper Tool (x2)

**NB:**

The STI-6200 comes complete with everything needed for a single extinguisher installation

## SPECIFICATIONS

<b>Housing</b>	3mm polycarbonate
<b>Dimensions</b>	136mm H x 136mm W x 50mm D
<b>Power Source</b>	9 VDC Alkaline
<b>Sounder Output (at 1 metre)</b>	95 dB - low/ 105 dB - high
<b>Operating Cable</b>	3mm galvanised steel
<b>Standby Current</b>	None
<b>Alarm Current</b>	40 mA at 95 dB / 150 mA at 105 dB

\* 12 VDC and 24 VDC models are available

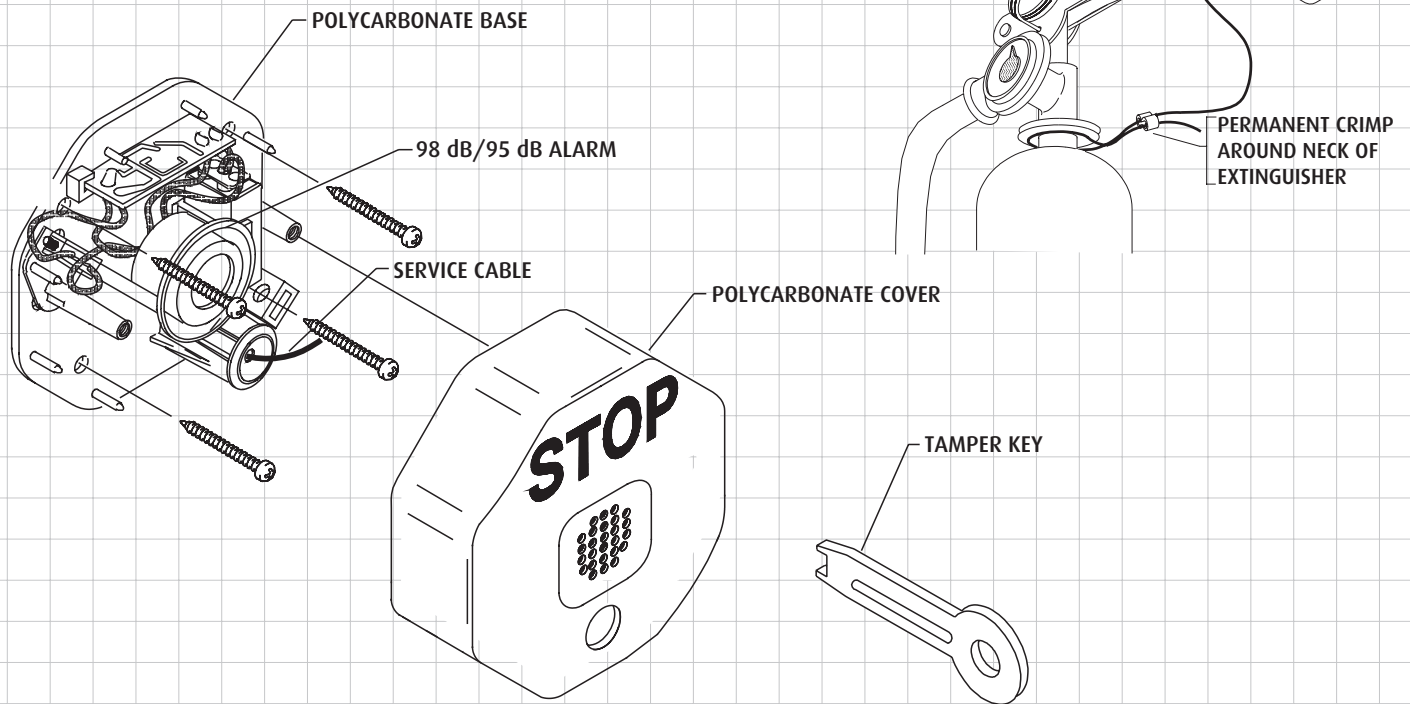
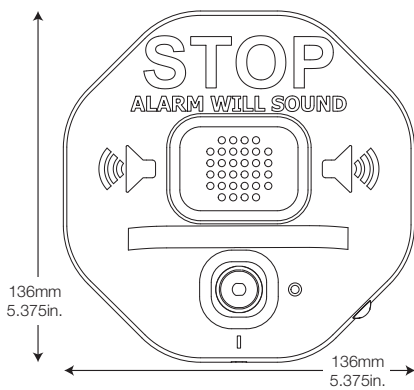

**Safety Technology International**

Taylor House  
34 Sherwood Road  
Bromsgrove  
Worcestershire  
B60 3DR, England

Tel: +44 (0)1527 520 999  
Fax: +44 (0)1527 501 999  
info@sti-emea.com  
www.sti-emea.com

2306 Airport Road  
Waterford, Michigan  
48327, USA

Tel: 248-673-9898  
Fax: 248-673-1246  
Toll-free: 0800-888-4784  
info@sti-usa.com  
www.sti-usa.com